

SECTION X - X

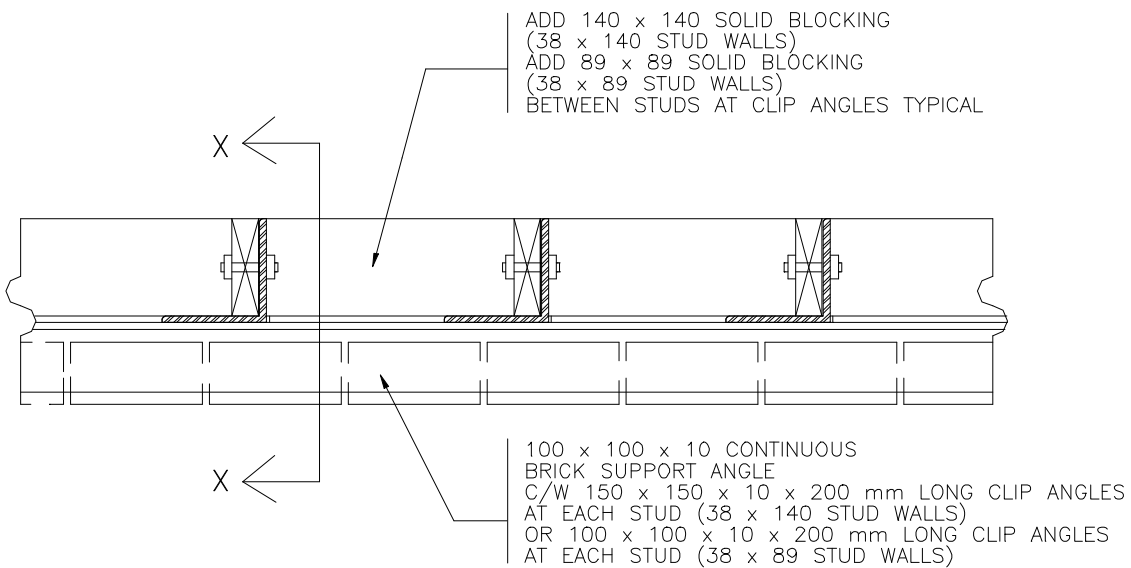

PLAN

Detail 9.3 – Section Through Brick Veneer Supported by Truss